

Reflection & Refraction, Stars pages 37-38 **(Dark Room)**

Be Careful with the Laser!! This laser, pointed into an eyeball, can do serious permanent damage (and you won't feel a thing). Remember that the beam will reflect and/or refract off any surface it hits. Make sure no eyeballs are in dangerous positions (above the water's surface, or at the two small ends of the tank as seen below).

Start with the beam vertical, as shown at right. Then, making sure no eyeballs are in the way, rotate the laser so the beam hits the water's top surface at as large an angle as possible. (This is the "angle of incidence" mentioned in the text.)

On the figure, **sketch** what happens to the beam (dashed line) as it enters the water in this case. This is an example of _____. Also **sketch** in a line perpendicular to the water's surface. If we used a red laser instead of green, what would you expect to be different?

Now aim the laser into the water from the side, towards the top surface. **Sketch** the path of the beam within the water for this situation on the figure shown at right. This is an example of _____.

Why do you think it is easier to see the laser beam when it is in the water than when it is in the air? _____

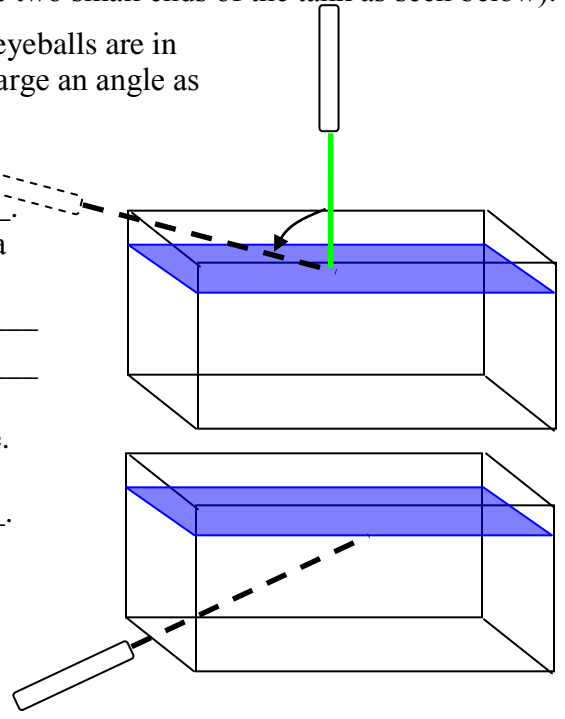

Dispersion, Stars pages 36 & 39 **(Dark Room)**

Set up the light as shown in the bird's eye view at right. (The line of white light should not be pointed at the screen.) Hold the prism as shown and try to get a spectrum to land on the screen. What order are the colors in? _____

Which color is "bent" the most? (That is, which one appears toward the bottom of the page in the diagram at right?) _____

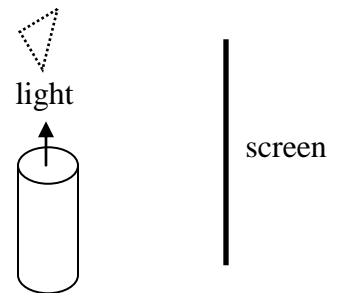

Now put down the prism and try the diffraction grating. How many separate spectra can you get to appear simultaneously? _____

Lastly, hold the CD at an angle in the light beam and look for rainbows. Why does the CD also produce a spectrum? _____

More Refraction (*only if you have time at the end*)

Take a flat glass rectangle and hold it flat size up (like a square frisbee). Look through the skinny clear side at your finger held vertically on the other side. Change the angle of the glass slightly by rotating in the plane (like spinning a frisbee on your finger). What happens to the image of your finger as you rotate the glass? Why?

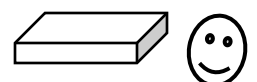

Diffraction, Stars pages 38-39 (Dark Room)

With the laser off, use the flashlight to read the labels on the notched wheel. Turn on the laser with the slider switch on its back. **Be careful not to hit any eyeballs!** Rotate the wheel so the laser passes through the skinny end of the “variable slit” option. Slowly rotate the wheel to the fat end of the slit, watching what happens to the pattern, then **sketch** in the upper box the final pattern you see on the screen. (Walk closer to the screen to see faint details!) Compare this with the diagram on p. 39 of the text, and **label the locations of c_0 , both c_1 , and both $d_{1/2}$** on your sketch.

Now rotate the wheel so the laser passes through the larger “circular aperture” option, and **sketch** what you see in the lower box.

Read the paragraph about resolution and diffraction on pages 42-43 of the text, then **label** the “central fringe” (or “diffraction disk”) in your sketch.

Doppler Effect, Stars page 40 (on computer)

Light and sound are both waves, so they both exhibit the Doppler effect. First go to <http://www.walter-fendt.de/ph11e/dopplereff.htm> and watch the ambulance pass the pedestrian.

Is the frequency of the sound waves arriving at the pedestrian higher or lower after the ambulance has passed?

Is the wavelength heard by the pedestrian longer or shorter after the ambulance has passed?

If this were light instead of sound, would the light be redder or bluer after the ambulance has passed?

Now go to <http://www.colorado.edu/physics/2000/applets/doppler2.html>. (Try not to absorb the social commentary while listening to the sound - it's the only site I can find with sound!) Listen to the car go by and figure out roughly where you must be standing in the picture based on the change in the sound. **Mark** your location in the sketch at right.

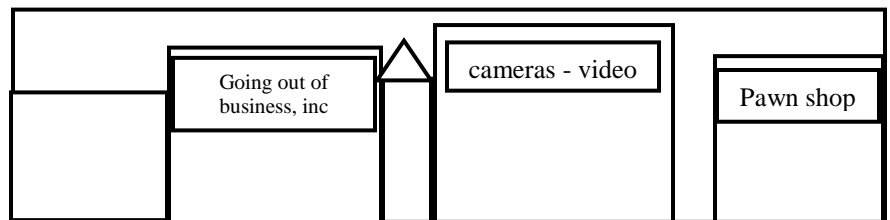

If you were inside the car as it moved, how would the sound be different?

Build a Refractor, Stars pages 40-44

Hold the lens in the black frame at arms length so you can see the eye chart through it. Hold the larger unframed lens (“A”) near your eye and sight through it to the framed lens, then move it in and out until the eye chart comes into focus. Repeat this experiment with the smaller unframed lens (“B”). Consult p. 41 of the text to help answer the following questions.

Which “eyepiece” lens gives more magnification, A or B? _____

Which eyepiece lens has a longer focal length? _____

Which eyepiece is harder to line up properly to see through (this means it has a smaller field of view)?

Examine a Reflector, Stars pages 45-46

Look into the barrel of the telescope from both ends. Compare what you see with the diagrams by the telescope and those in your text.

What is the name for this telescope design? _____